



RECOIL[®]

PWS10D2/PWS10D4

ECHO PRO 10" SHALLOW SUBWOOFER

User Manual

BEFORE YOU START - CONGRATULATIONS!

Congratulations on your purchase of our product! We hope that RECOIL subwoofers will delight you with impressive performance. In the production of PWS subwoofers, high-quality components and ultramodern materials are used. This manual contains the basic instructions required for the correct installation and use of the system. Before installing the components, please read all instructions in this manual carefully. Failure to follow instructions can result in unintentional damage or product damage.

TO install PWS series subwoofers, it is recommended to contact a professional car audio installation service. Correct acoustics setting allows you to achieve excellent sound and extend the service life. If there is any question, please contact support@recoilaudio.com

PRECAUTIONS

ATTENTION!

Prolonged exposure to sound pressure 100 dB and higher can cause hearing loss. Use common sense and practice safe sound. Remember that prolonged exposure to excessively high sound levels can damage your hearing. Driving safety comes first.

The manufacturer is not responsible for hearing loss, body damage or property damage due to misuse of this product.

Proceed with the installation only if you are a qualified car audio installer, otherwise contact a professional installation service.

- Always wear safety glasses when using tools.
- Before proceeding with the installation, turn off the car head unit and other electronic devices.
- Disconnect the negative (-) terminal from the car battery before starting the installation.
- Store the loudspeaker in its packaging if you have not proceeded to install it, and always place the loudspeaker with the cone facing up. Never use force when installing speakers.
- Determine the location of the fuel lines, brake pipes, oil lines, and vehicle electrical wiring before proceeding with the installation.

- Check that the installation site has sufficient air exchange on both sides of the speakers before drilling holes.
- Check that nothing interferes with the normal operation of the cone, otherwise the cone will be damaged.
- Use a utility knife to cut off excess pieces of fabric near the hole where the speaker will be installed before starting drilling.
- Use a grommet for the speaker wires (not included) when pulling through sheet metal, otherwise the wire may be damaged by the metal edges of the hole.

PACKAGE CONTENTS

Subwoofer - 1 pc

Instruction - 1 pc

Mounting Screw Pack - 4 Pairs

SPEAKER CONNECTION EXAMPLES

Your subwoofer speakers have a dual voice coil and $2\Omega/4\Omega$ impedance. You need to know the maximum power of your amplifier to optimize your sound. You can vary the impedance parameter by connecting the woofer acoustics: in series, in parallel or mixed. Please select a suitable woofer speaker connection scheme depending on the number of speakers to be connected through the speaker system and the stability of the amplifier impedance. The most important thing when connecting speakers is to make the connection so that none of the speakers are overloaded. Overload threatens to damage the speaker. It is important to understand that the speaker can be powered either less or equal to the rated power for which it is designed. Otherwise, any speaker will be damaged due to overload. Before connecting the speakers, you need to determine their nominal power (W), the active resistance of the voice coil (Ohm), which are indicated on the magnet or in the technical specifications in the attached instructions.

Parallel Wiring

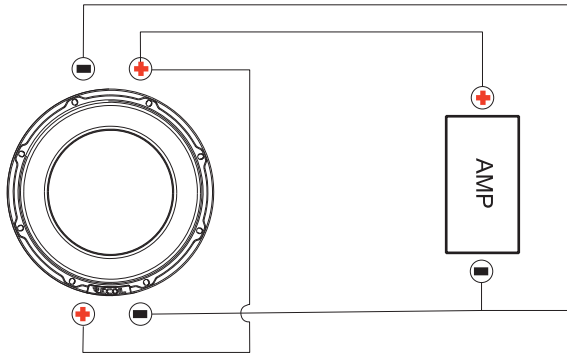

Serial Wiring

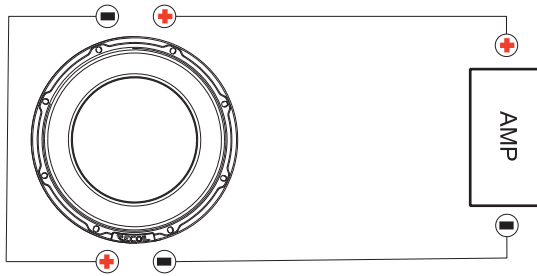

Parallel/Serial Mixed Wiring

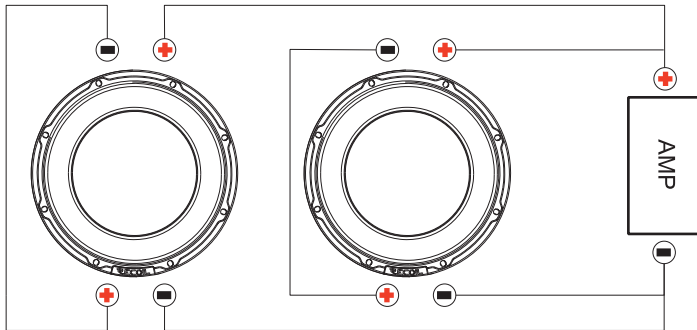

	PWS10D2	PWS10D4
Speaker (1 PC)	2+2	4+4
Parallel Connection (2 PCS)	0.5/2	1/4
series connection (2 PCS)	2/8	4/16
Connection	Measurements in Ohm (Ω)	

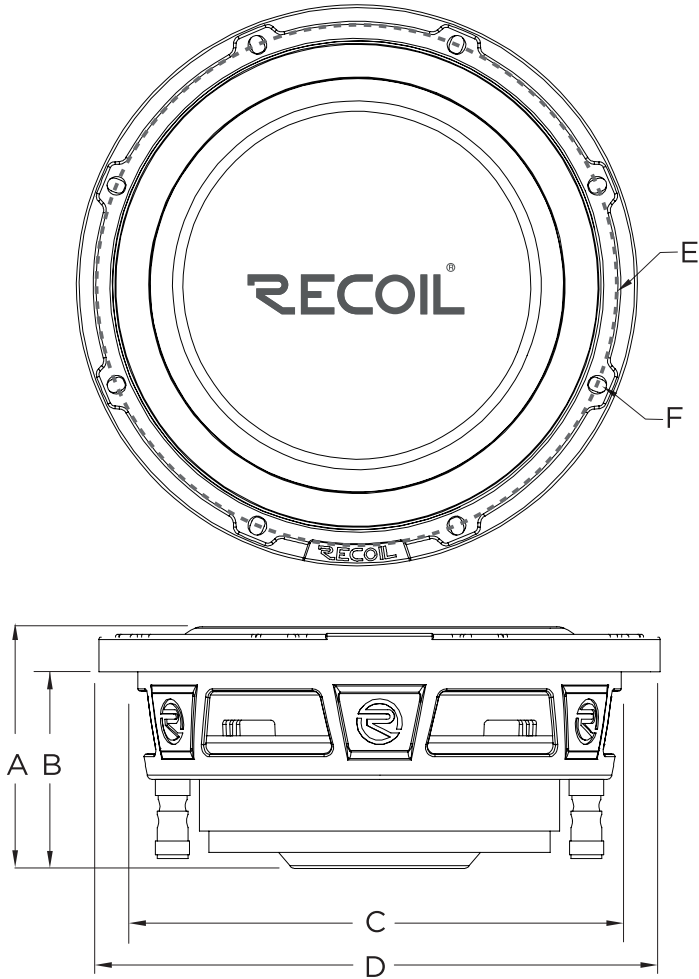

PWS10 series subwoofer size table						
Code	A	B	C	D	E	F
PWS10D2 PWS10D4	101.5	77	232	262.5	246.5	5

Unit:mm

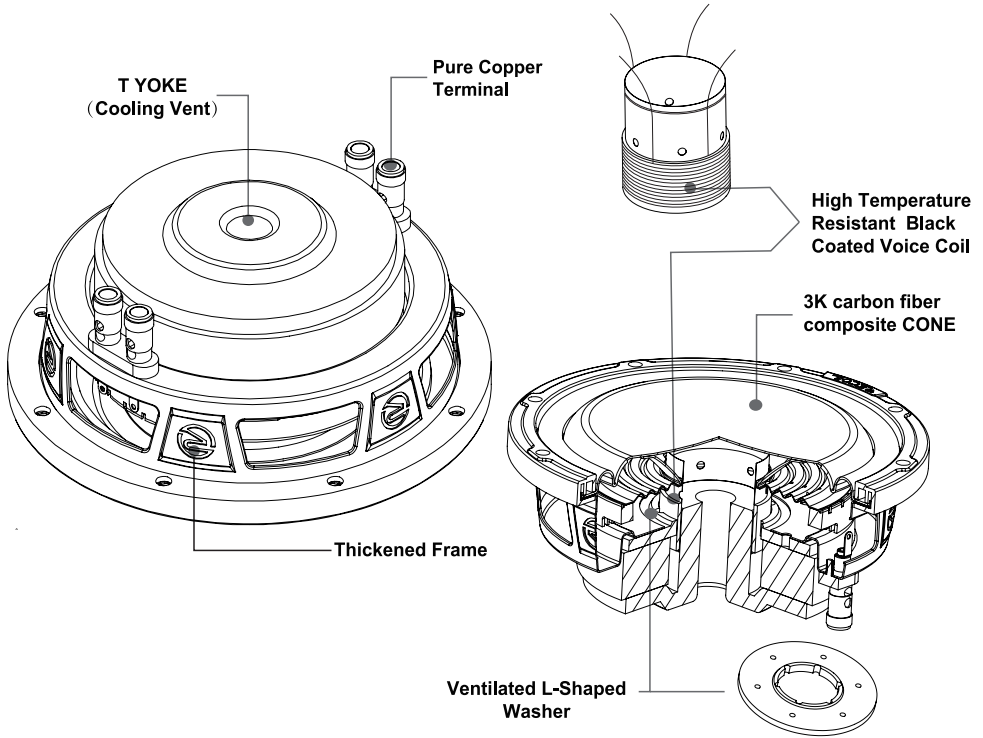

Why Use a Subwoofer Enclosure?

This is a very complicated and overly discussed topic. For over 80 years manufacturers and hobbyists have discussed, debated the virtues of having enclosures, vented (ported) versus sealed versus bandpass versus transmission lines.

TYPES OF ENCLOSURES

SEALED

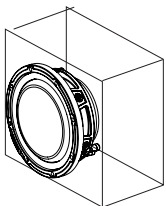

VENTED

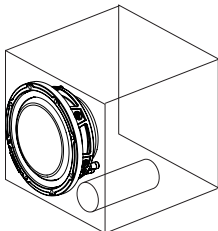

BANDPASS

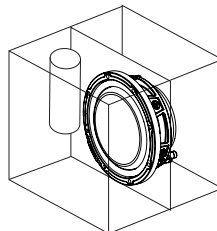

TRANSMISSION LINE

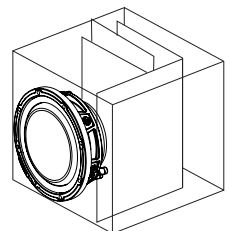

It is beyond the scope of this tech tip to discuss all the virtues (pros and cons) of each. We will keep the discussion to sealed versus vented as these are the 2 most commonly used enclosures for car audio applications.

Remember there are 2 types of energy in car audio. Electrical, which ISN'T free, and acoustical – which is FREE. Typically no one complains to their retailer/installer that they got TOO MUCH BASS! Everyone complains about not getting enough!!! So lets FIX that! Design and build better subwoofer enclosures.

SEALED

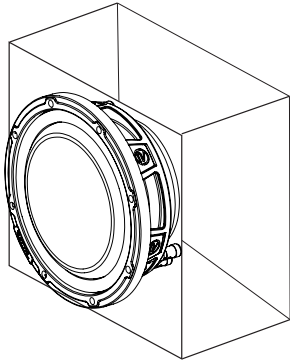

PROS & CONS?

SEALED: Advantages

1. Simple to build, no real thinking involved.
Hard to screw up
2. Best phase and time response.

SEALED: Disadvantages

1. Lose typically 3 - 6dB of output versus vented
2. You'll need 6dB more power to get to the same point in output as a vented enclosure. Or like going from a 500 watt amplifier to a 2,000 watt amplifier. And the subsequent additional current draw. 500 watts is about 58 amperes, versus 2,000 watts which is 233 amperes (full power current draw)

TYPICAL RECOMMENDED TUNING FREQUENCIES



For 4 door sedans 34-38 Hz

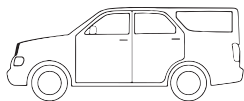

For longer vehicles (SUV's ,Vans, etc) typically 30-36Hz

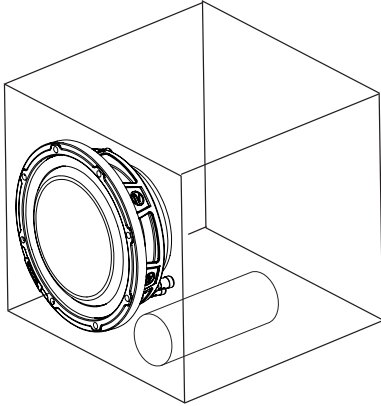
VENTED**PROS& CONS?****VENTED: Advantages**

1. Gain 3-6dB of output over sealed. Or roughly the equivalent of having a 500 watt amp "act" like its 2,000 watts. Enclosure is giving you FREE energy
2. Better transient response.
3. Less current draw because you can utilize a smaller amplifier.

VENTED: Disadvantages

1. Much harder to design and build. Really need a modeling program to do that. We recommend WinISDPro. Which is FREE go to this URL: <http://www.linearteam.org/>
2. Typically about double the size of a sealed enclosure. But still relatively small in the scheme of things.
3. If you design the box incorrectly (in other words mistune it) for example tune below F_s of driver {highly discouraged} it can damage the woofer

PREFABRICATED ENCLOSURES: PROS AND CONS

These can be "OK". BUT...the secret is don't get one that is tuned TOO high. Many of these prefab enclosures are tuned to 40 Hz. For most "mature adults, this tends to be too high. Typically no one complains to their retailer/installer that they got TOO MUCH BASS! Everyone ,complains about not getting enough!!! So lets FIX that!

- Design and build better subwoofer enclosures-

There are all kinds of ways to design subwoofer enclosures. Nomograms, charts, on-line design software, etc. But the BEST most consistent PC software is available...and better yet...its FREE!

And it has been available for over 10 years.

WinISD

<http://www.linearteam.org/>

(HINT: only put in 4 of the Theile/Small Parameters - F_s /Vas/Qes/Qms)

Tech Tips/Secret Stuff

1. Use 3/5 in or thicker MDF, or Baltic Ply (perfered)
2. When in doubt BRACE! Woofers can produce MORE than 10 pounds per square inch of pressure!
3. Always deaden the interior (if possible) with deadliner, Recoil Audio DynaMat, HushMat, etc. Make the enclosure as dead as possible.
4. Stuff enclosures about 1/2 to 2/3rds full of polyfill. BOTH for vented and sealed!
5. IF there is a choice between vented OR sealed. For a normal human being...go VENTED!!!!
Sealed? You need 4 times the energy (power) to get to the same place a vented can get you.
And some of the most expensive home speaker systems in the world...use vented enclosures!!

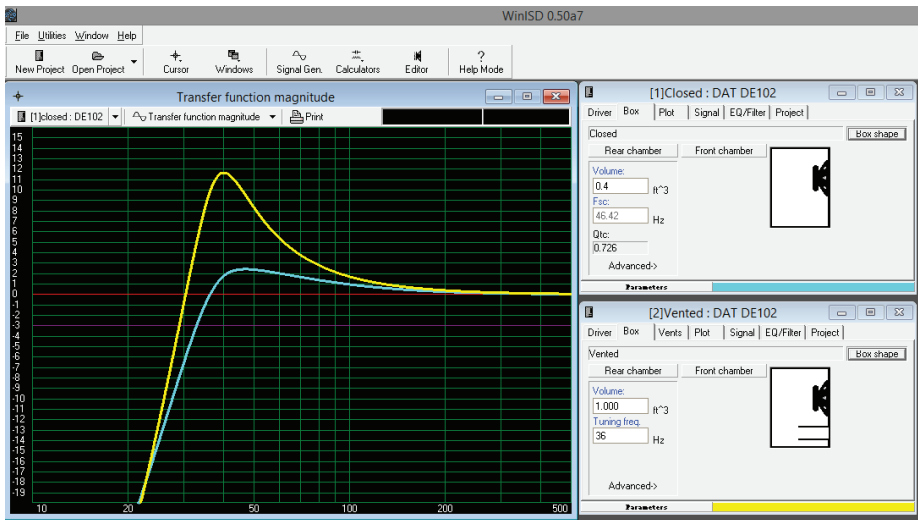

**IN THIS "SCENARIO" A 0.4 SEALED VS 1.0 CUBIC FT VENTED ENCLOSURE
VENTED IS +9 dB more output for every watt put into it!!**

The enclosures specified below are offered as suggestions only. Assistance from an authorized Recoil Audio retailer is recommended for designing the correct enclosure for YOUR system. All volumes are shown as gross internal volumes, driver and vent displacement have been accounted for.

NOTE:

The use of a 30Hz sub-sonic filter is recommended on most vented enclosures

Vented

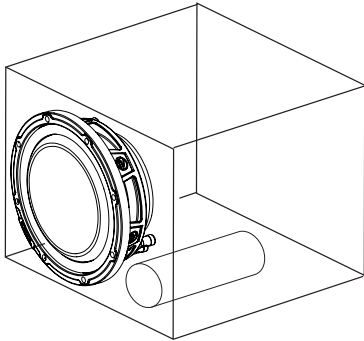

Sealed

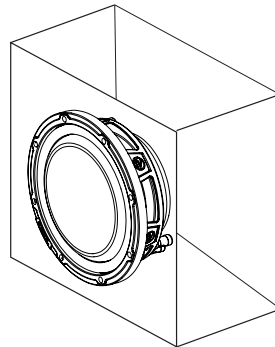

	Vented	Sealed
L (mm/in.)	550/21.7	500/19.7
W (mm/in.)	180/7.1	170/6.7
H (mm/in.)	320/12.6	300/11.8
Port/s Dia (mm/in.)	95/3.74	N/A
Port/s Length (mm/in.)	630/24.8	N/A
MDF Thickness (mm/in.)	18/0.7	18/0.7
MAX POWER(W)	800	800
Vb (L/FT3)	38/1.34	15.5/0.55

Parameters

Test items	PWS10D2	PWS10D4	UNIT
Nominal Impedance	2+2	4+4	ohms
RMS Power Handling	350	350	Watts
MAX Power Handling	700	700	Watts
Frequency Response	34-350	34-350	Hz
Voice Coil Diameter	2.5/63.5	2.5/63.5	in/mm
Winding Material	ASV	ASV	N/A
Diaphragm Material	CARBON FIBER	CARBON FIBER	N/A
Frame Material	Steel	Steel	N/A
Magnet Material	Ferrite	Ferrite	N/A
Magnet Weight	2296/81	2296/81	g/Ounce
Xmax	0.39/10	0.39/10	in/mm
T/S parameters (parallel connection)			
Revc	1	1.6	Ohm
Spl	84.4	85.2	dB
F0	34	36	Hz
Qts	0.43	0.46	N/A
Qes	0.54	0.54	N/A
Qms	2.1	2.97	N/A
Vas	24.3	25.3	L
n0	0.173	0.21	%
CP	2863.7	2884.2	uF
Cms	0.13	0.14	mm/N
BL	8.18	9.8	N/A
Mms	167.9	143.2g	g
Sd	363.1	363.1	cm ²
Dimensions			
Overall Depth	4/101.5		In/mm
Mounting Depth	3.03/77		In/mm
Overall Width	10.33/262.5		In/mm
Cutout Diameter	9.13/232		In/mm

User Manual



WWW.RECOILAUDIO.COM

COPYRIGHT© 2026 RECOIL ALL RIGHTS RESERVED. RECOIL, NINGBO AVS TECHNOLOGY CO., LTD AND DOMESTIC INVESTMENT GROUP, LLC ASSUME NO RESPONSIBILITY OR LIABILITY FOR FINES OR DAMAGES INCURRED AS A RESULT OF IMPROPER USE OF THIS PRODUCT.